



**BRODY 423**

# Warren Family Homes

Pty Ltd

QBCC: 1071913



Impressions for illustration purposes only

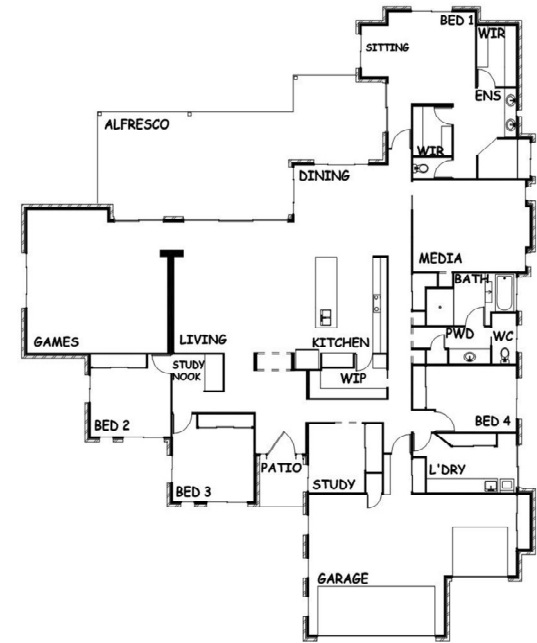

### **Features:**

- 4 Bedrooms + Study
- 2 Living
- 1 Media
- 2 Bathrooms
- 3 Car Spaces

### **Floor Areas:**

- Dwelling: 367.0 m2
- Alfresco: 52.3 m2
- Patio: 4.0 m2
- Total Area: 423.3 m2

### **Dimensions:**

- Width: 22.99 m
- Length: 28.32 m (gutter to gutter)



## Bundaberg's Most TRUSTED & RELIABLE Builder

P: 07 4159 0222 E: [bundy@warrenfamilyhomes.com.au](mailto:bundy@warrenfamilyhomes.com.au) W: [www.warrenfamilyhomes.com.au](http://www.warrenfamilyhomes.com.au)

Visit Bundaberg's only fully complete builder's display centre at 51 Princess Street, Bundaberg East, QLD, 4670

